

---

# Comparison of New Bulk Strength Measurement Technique with Traditional Schulze (direct shear measurements) Method

By: Dr. Kerry Johanson  
Material Flow Solutions, Inc.

---

## Introduction

Bulk solids behave differently from typical fluids. When a fluid is placed in a container with an opening, it flows through that opening. The question to be answered is: how fast does it pass through that particular opening? However, when a bulk solid is placed into a container and then allowed to flow, it may or may not pass through the opening. This difference in behavior between liquid and solid is a result of the unique differences between fluids and powders. A powder can maintain and resist different stresses in different directions within the bulk. The same cannot be said of liquids.

Consider a simple fluid at rest in a container. The pressure at a given point two meters down from the top surface will be a unique value, irrespective of the direction of the container wall or even if the surface is an internal surface or an external surface. If the fluid is in contact with the surface at this prescribed elevation, the magnitude of the pressure will be a unique scalar value. The situation with powders is much more complex. Now, consider a powder coming to rest in a container. At any point within the powder, there can be different stresses acting in mutually orthogonal directions. It is entirely possible that near the container outlet the stress level in the direction of the outlet can be zero, while the stress level acting against the container wall near the outlet may be significant. In fact, if the material possesses a quality called unconfined yield strength, and the stress against the wall is less than this yield stress, then powder strength can cause the complete stoppage of flow from the outlet, resulting in the formation of a stable arch across the outlet. Unconfined yield strength is defined as the major principle stress acting on a bulk material in an unconfined state that causes that material to initially fail or yield in shear.

For the process engineer, strength is the key property that determines if a bulk material will arch or form stable ratholes in process equipment. Since the goal of powder processing is to maintain reliable flow, arching and rathole tendencies are considerable problems. Strength is a far reaching flow property that controls the behavior of the bulk material in many processes. Excessive powder strength may make the bulk material difficult to fluidize, resulting in channeling and poor process control. Excessive strength may make blending impossible. Excessive strength can cause powder material to

agglomerate when it is agitated. Excessive strength can cause material to arch over die cavities, making capsule filling and tablet production difficult at best. Strength can cause weight variations in filling machines. Excessive strength can also cause powder to form stagnant zones during operation.

However, sometimes bulk strength is a good thing. Just the right amount of yield strength may prevent unwanted particle segregation in powders. Strength can cause compacted material to hold together after compaction, making tableting and ceramic part production possible. And, in a serendipitous twist of fate, strength will cause a cohesive bulk material to agglomerate in roll press operations, allowing for the formation of easily handled materials and preventing many of the problems caused by bulk strength.

With so many powder flow behaviors depending on the bulk unconfined yield strength of the material, measurement of this key property should have a prominent position in standard powder characterization tests done in pharmaceutical, chemical, ceramic, powdered metal, food, cosmetic, battery, and nutraceutical industries. It should be measured almost as frequently as particle size to quantify potential flow problems in key process areas. Bulk strength measurements can provide early warning of potential process upset caused by arching and ratholing. Thus, it is an ideal measurement for quality control of powder processes. So, why are bulk strength measurements used so infrequently to characterize bulk powders? The answer lies, in part with fact that many of the current methods to measure this quantity require significant technician training to get reliable results. If the method were as simple as filling a test cell and letting the machine do the rest, then it would be used more often. The answer also lies in the fact that many of the existing test methods require a significant amount of bulk solid material. Often getting this amount of material is difficult, or the material is expensive. If a testing method was created that required only as much material as was used in a typical laser diffraction particle size analysis, then more bulk unconfined strength measurements would be conducted. Finally, the answer to the question lies in part with the time required to run typical bulk solid strength tests. Generally, this measurement process requires several hours of testing and calculation to acquire reasonable results. If the strength measurement could be accomplished in a matter of minutes, then more measurement of bulk cohesive strength would be done and engineers could use the to correlate product characteristics with process behavior.

It is important to note here the importance of being able to measure a flow property that directly correlates to problems in the process. All too often engineers rely on secondary measurements to correlate material strength to process behavior. For example, particle size is an easily measured property that many engineers use to predict process behavior. However, let's suppose that the real process problem is the fact that a particular dust collection system receiving vessel is constantly becoming plugged with

powder during operation. It is entirely possible that the upstream process is creating consistently sized particles, but that changes in moisture content, static charge, particle hydrophobicity, particle roughness, or even particle shape are the cause of these cohesive hang-ups. While it is true that changes in particle size can cause differences in bulk strength, there are a half dozen other reasons that the bulk yield strength of a powder may change. While there is some merit to understanding the cause of cohesive strength, frequently we simply want to identify the problem and change process variables to prevent the cohesive hang-up issue. In these situations, it is much better to measure directly the property that is causing the problem in the process (bulk unconfined yield strength) than to have to measure many properties (size, shape, moisture content, surface roughness, and surface energies) and infer the effect of each on the primary property of interest (bulk strength).

In some cases engineers do wish to understand the relationship between particle scale properties and bulk unconfined yield strength. To undertake a rigorous study of which variables create bulk unconfined yield strength of fine powder, we will need an easy method to measure strength that is relatively fast, does not require much material, and covers the full range of stresses the material may be subject to.

This paper highlights a new test methodology that allows the user to easily measure the bulk strength of a small ~0.1 cc sample of material in just a few minutes. As an added bonus, the test method will allow the user to measure cohesive strength values at consolidation pressure two orders of magnitude smaller than currently possible using existing test equipment. This low pressure measurement capability is advantageous since many hang-ups occur in the low stress regions near the outlet of small diameter hoppers or over the small die cavity during filling of a compaction machine. Often weight variation in tablets is due to problems in the initial die or capsule filling process. Traditional strength measurement methods cannot measure the key cohesive flow properties at these low stress values, and extrapolation must be used to estimate bulk strength at low stress values found in real powder processing systems. This new technique allows direct measurement of unconfined yield strength at low stress levels – as low as 10 Pa. This paper describes a new method for measuring the unconfined yield strength of bulk powders, and compares strength measurements obtained with this novel method to traditional measurements from direct shear testers like the Schulze tester commonly used in industry.

## **Measurement Methodology**

Simply put, the test technique is to place a small quantity of material into an enclosed conical cavity; consolidate it using centrifugal force; then remove the obstructions at the bottom of the conical cavity and use centrifugal force to cause material to fail, yield or extrude from the cavity. The process is summarized in steps 1 through 4 below. The key parts of the test procedure are highlighted below:

In the first step, a guard is inserted below the smaller diameter opening of the conical orifice and material is placed carefully into the cell by passing or vibrating the powder through a coarse sieve to break agglomerates. The gentle fill process reduces the over-compaction pressures that arise during filling. This necessary step allows for strength to be measured at very low consolidation pressures. Over-consolidation due to handling should be reduced. This is not as critical when doing measurements at large consolidation pressures.

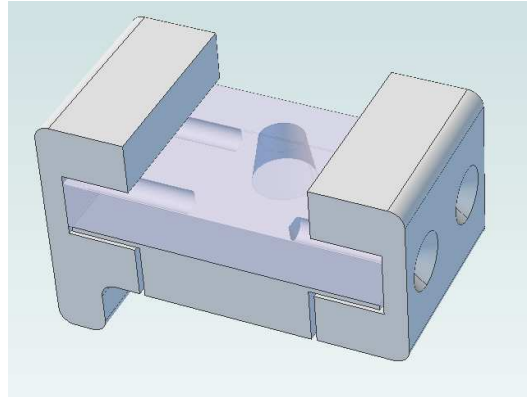

### **Step 1**

The second step involves placing a guard at the top of the cell and then setting the cell in a rotary cavity such that the axis of the conical cavity is 90 degrees from the direction of rotation.

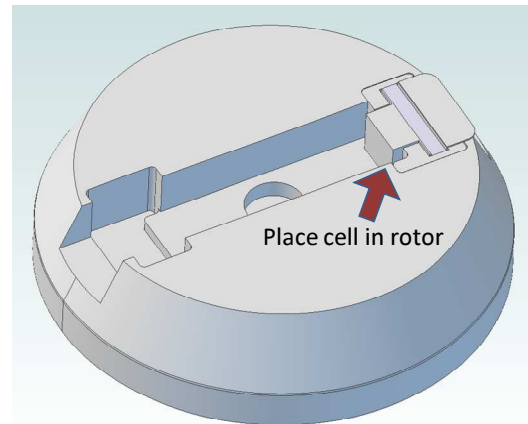

### **Step 2**

The third step involves rotating the cell and rotor to a prescribed speed and holding at that prescribed speed for an allotted time. This causes centrifugal forces to act on the bulk material in the conical cell and compact the material within the cell. The rotor speed and the weight of the material, along with the position relative to the axis of rotation, are used to compute the consolidation pressure.

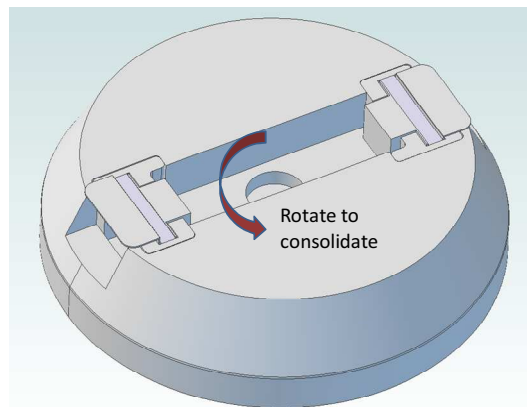

### **Step 3**

The fourth step involves stopping the rotation and removing the guards. The bulk material presumably has strength and will arch over the conical cavity. The rotation speed is increased incrementally until the compacted material exits the conical cavity due to centrifugal force. The weight of the material, the position relative to the axis of rotation, and the rotation speed at the point when the material leaves the cell are used to compute the force needed to fail the compacted material in the conical arch. This data is then used to compute the bulk unconfined yield strength.

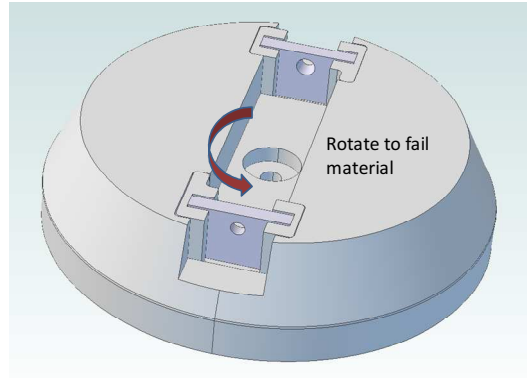

#### **Step 4**

#### **Test Time Requirements**

The complete process requires about 0.1 cc of material and can be completed in just a few minutes. The user interface requires filling a cell and removing a couple of guards at key points during the test. The test technique can be accomplished in a matter of about 5 minutes for each strength measurement of interest. If you are concerned with quality control, this is a very reasonable time expenditure to check the cohesive properties of powder created by the process. If you are in the design or research mode where you need to develop a complete strength profile as a function of compaction pressure, it will require about 30 minutes and 0.6 cc of material to generate a six point strength profile and fully characterize the hang-up behavior of the bulk material. If you are a formulation engineer attempting to design a free flowing material by adding flow-aids or glidants to the formulation, you can fully examine the effect of 5 flow-aid concentrations at six compaction pressures in about 2.5 hours. This methodology allows engineers to generate the data, determine the optimal flow-aid concentration, write the report and send it to their boss, all before going to lunch. The same task, using traditional techniques, would require several days of testing and data extrapolation to accomplish.

#### **Comparison of Data**

From 1989 through 1992 the European solids flow community conducted some research into the standardization of flow properties measurements [1][3] using a standardized material. While the concept of being able to create and maintain a standard test sample to be used for calibration of test equipment is still a topic of controversy, this standard material – BCR limestone – has been used to compare test equipment measuring bulk unconfined strength of powder materials. We collected direct shear measurement data from two past researchers [5][6] as well as

independently measuring the bulk unconfined yield strength of a current sample of BCR limestone with a Schulze direct shear tester [2]. This data is presented in Figure 1.

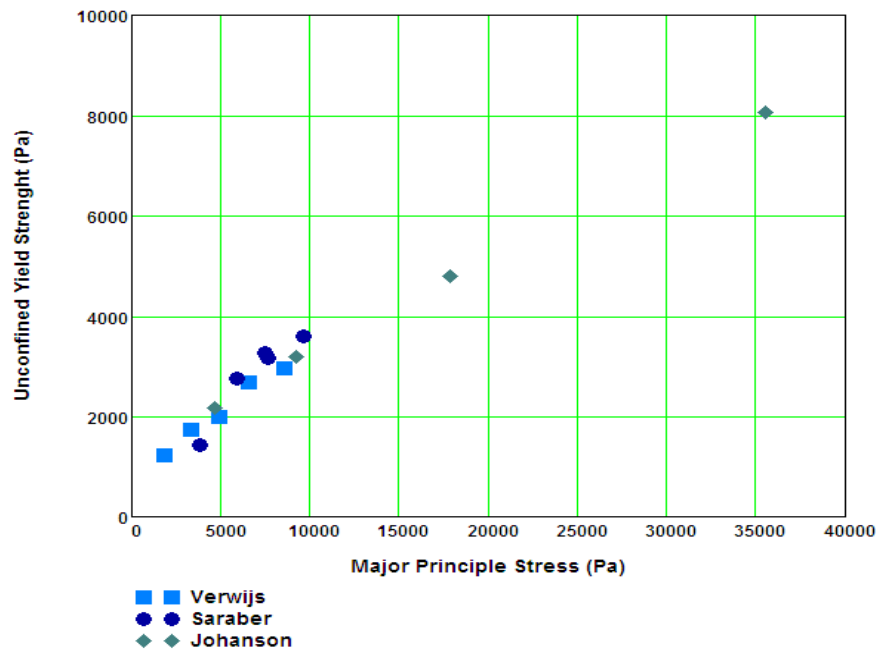

**Figure 1. Comparison of BCR Limestone data generated from three different studies**

This data spans a fairly wide range of major principle stress values between 1,700 Pa and 36,000 Pa. It is important to note that the available data is limited to stress values above 1,786 Pa. This is due to the fact that the direct shear test technique cannot reliably generate strength data at solids stress levels much below this value. In some instances, researcher have been able to approach strength measurements for some materials at pressure as small as 1,000 Pa, but there is usually a fair degree of error in these measurements. It is also important to note that the collection of data shows that the strength as a function of major principle stress is a non-linear function and tends to level off as the stress level increases, although, one could argue that, for at least some stress ranges, the data generated from this direct shear test technique can be approximated by a linear curve.

We also measured the bulk unconfined yield strength using the new method described above (commercially available as the SSSpinTester). We measured the bulk unconfined yield strength at 26 distinct stress levels between 30 Pa and almost 30,000 Pa. This data is presented in Figure 2. Note that the data from the SSSpinTester fits with the data generated using the direct shear method of all three researchers over the major principle stress levels for the entire data set. This data shows a distinct non-linear behavior as a function of consolidation pressure.

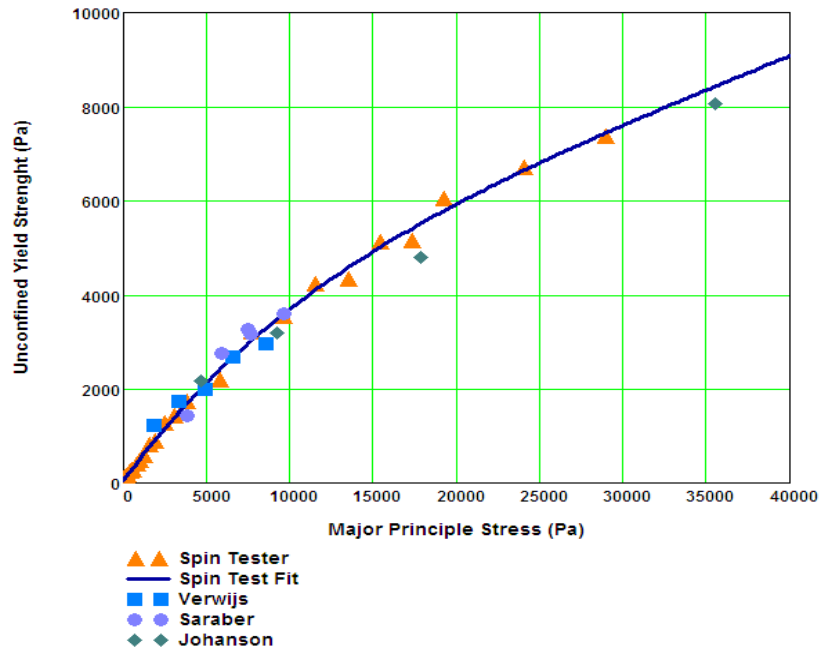

**Figure 2. Comparison of BCR limestone data generated from three different studies and new test technique (SSSpinTester)**

Now, consider the data in the lower pressure range of the curve (Figure 3). Strength values measured for major principle stress levels below 5,000 Pa are plotted in this figure, including data from other researchers as a comparison. It is evident in this figure that the strength points measured from the new test method (SSSpinTester) pass through the middle of the data points from other researchers. It is also evident that there are 10 additional strength measurements at consolidation stress values between 1,786 Pa and 30 Pa, suggesting that the new test method has extended the test measurement range almost two full orders of magnitude. It is now possible to characterize the strength of bulk solids at consolidation pressures down to 30 Pa with reasonable repeatability..

We also measured the bulk unconfined yield strength of Argo corn starch using both the Schulze direct shear tester and the SSSpinTester (Figure 4). Note the good agreement between the data.

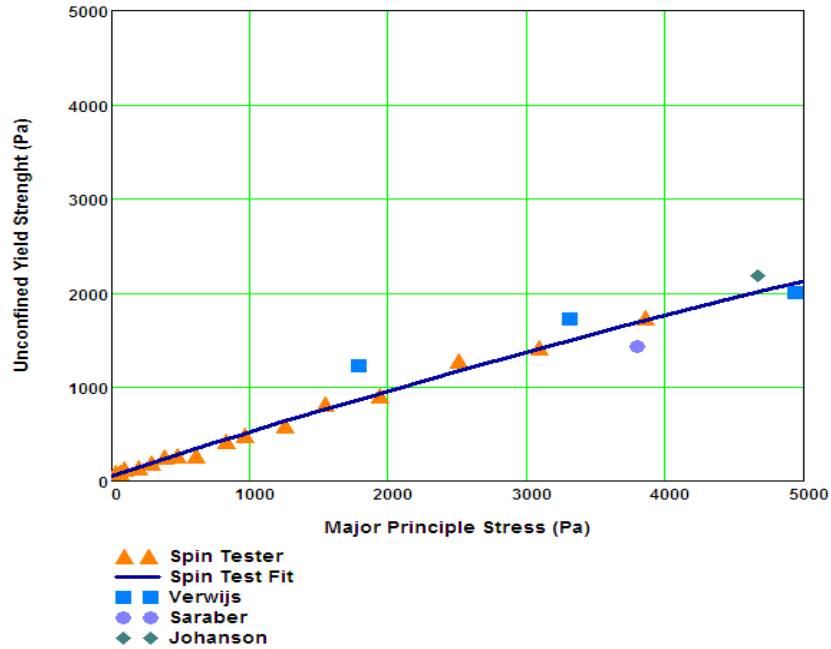

**Figure 3. Comparison of low stress level BCR limestone data generated from three different studies and new test technique (SSSpinTester)**

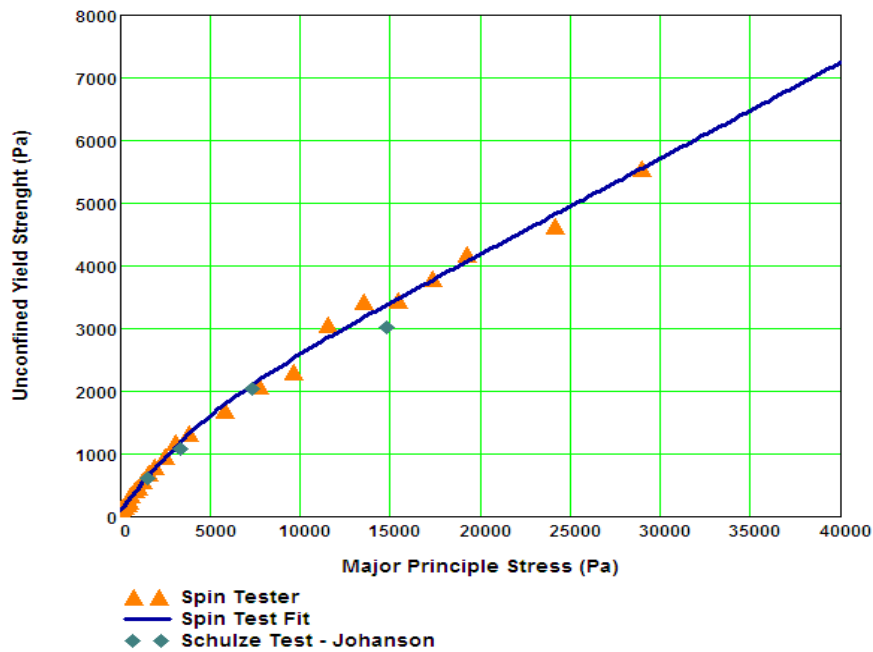

**Figure 4. Comparison of the unconfined yield strength of Argo cornstarch measured with the Schulze direct shear method and the new test technique (SSSpinTester)**



The strength values for cornstarch are lower than the strength values for the limestone. However, this material would still be considered a cohesive material. Both the Schulze data and the data obtained from the SSSpinTester indicate that the strength tends to level off considerably at higher consolidation stress levels. The lowest stress level that we could measure with the Schulze test was about 1,500 Pa, but we were able to generate 11 points between 1,500 Pa and 30 Pa using the SSSpinTester method (Figure 5).

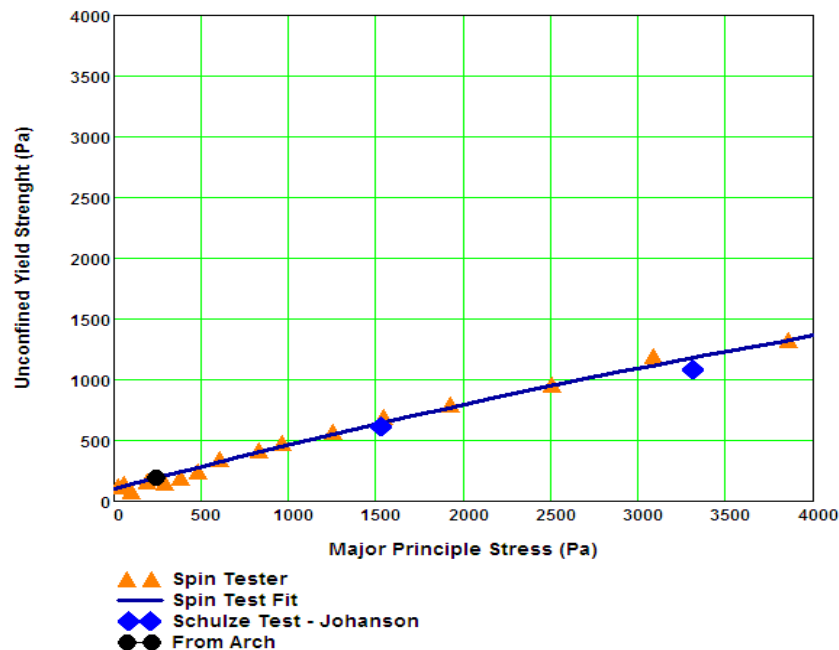

**Figure 5. Comparison of the lower stress level unconfined yield strength of Argo corn starch measured with the Schulze direct shear method and the new test technique (SSSpinTester)**

The astute and skeptical solids flow practitioner may suggest that one cannot really validate the strength measurements with standard testers in the low stress regime and, thus, one cannot really know if this tester is actually measuring strength in such a low pressure zone. The astute researcher would be correct. There is no way to validate the data using accepted direct shear measurement techniques. However, traditional strength measurements are routinely used to compute critical arching dimensions in conical hoppers and plane flow hoppers [4]. The theory used to predict these arches is well accepted and has been vetted for nearly three decades. This theory suggests that the arching diameter over a conical outlet is a function of the strength evaluated at a critical consolidation stress level (Equations 1 through 3).

$$AI = \frac{H_{\theta} \cdot fc_{crit}}{\gamma(\sigma_{crit}) \cdot g} \quad (1)$$

$$fc_{crit} = \frac{AI \cdot \gamma(\sigma_{crit}) \cdot g}{H_{\theta}} \quad (2)$$

$$fc_{crit} = \frac{\sigma_{crit}}{ff} \quad (3)$$

Where:

$\sigma_{crit}$  is the major principle stress level at the arch.

$fc_{crit}$  is the strength value at the arch.

$H_{\theta}$  is an arch geometry factor (2.2 for typical cone)

$ff$  is a flow factor that relates the stress in the arch to the stress required to break the arch (typically 1.2)

$\gamma$  is the bulk density of the powder.

$g$  is the gravitational acceleration

We placed the corn starch in various conical hoppers with different openings and found that it arched over an opening of about 8.8 cm. We then computed the critical strength and major principle stress associated with this arching condition and plotted that on the strength curve shown in figure 5 (black dot). There is excellent agreement between the strength computed from the arching analysis and the strength measured directly with the SSSpinTester. Thus, while there does not exist a standard tester to validate the strength data in the low pressure regime, the data is consistent with arching observations in real systems. Arching behavior can be used to validate the SSSpinTester at the low stress values, indicating the distinct advantage of using this test technique to measure bulk unconfined yield strength of powders especially in low pressure regimes.

A typical use for these measurements is to predict arching of bulk materials in hoppers and bins. The above example points out that the use of data from traditional techniques such as the Schulze test require extrapolation of strength data by at least one order of magnitude, a very risky extrapolation. Extrapolating an order of magnitude is asking a lot from a set of experimental data, even if the data is very good and consistent. However, this new test methodology uses interpolation to determine this value (a much safer analysis).

Finally, we measured the strength of FMC's PH-102 MCC using both the Schulze tester and the new SSSpinTester methodology (Figure 6). PH-102 MCC is a relatively free

flowing material, but it is also elastic in nature, often giving researchers and formulators a difficult time in acquiring reliable data from direct shear measurements. PH-102 MCC also seems to predict values that are not in line with observed arching behavior in process equipment. If you place FMC's PH-102 MCC powder in a conical hopper, you will find that the actual critical arching dimension is about 1.77 cm. However, it would not be uncommon for traditional shear methods testing PH-102 MCC powder to predict an arching dimension around 10 cm to 15 cm. Yet another researcher may test the same PH-102 MCC and predict a negative arching value. The issue is the accuracy of the direct shear methods when attempting to measure at very low strength levels. Note that the strength values from the Schulze measurement data appear to be concave upward, increasing more than a typical linear curve at higher consolidation pressure. If one includes the higher pressure data and uses linear least squares curve fitting routine to regress the data, then the resulting strength plot would predict a negative intercept on the strength axis. A negative result for the arching dimension would be predicted. However, if just the lower points are used to regress the PH-102 MCC data, then the strength plot may give a significant positive intercept of the strength axis, predicting a large positive arching dimension. There appears to be significant variability in the PH-102 MCC strength data measured with the Schulze tester.

One of the potential reasons for this variation is friction losses during shear using the Schulze tester. When measuring very low strength values the friction losses in the Schulze lever arm system for the normal load, as well as the friction due to the vanes scraping on the side of the cell, can cause significant changes in the yield locus during measurement. We will not go into a detailed analysis of the friction conditions in the test cell, but we will quantify their effects relative to PH-102 MCC.

For example, the load application level in the Schulze tester can cause a small (35 gm) change in the actual load applied to the material. This normal load may only vary by 1%, but it will result in a change in the measured yield strength value of 15% to 20%. Adding the other potential friction losses can cause strength values to vary by almost 50% at 4,000 Pa. These losses are not proportional to the normal load and, if the Schulze tester could measure at lower stress values, the error in the strength would be even greater due to friction losses in the tester. The bottom line is that measuring strength values less than 200 Pa using the Schulze tester is effectively impossible to accomplish with any degree of accuracy. This explains some of the scatter observed in the PH-102 MCC measurements with the Schulze tester (the blue diamonds in figure 6).

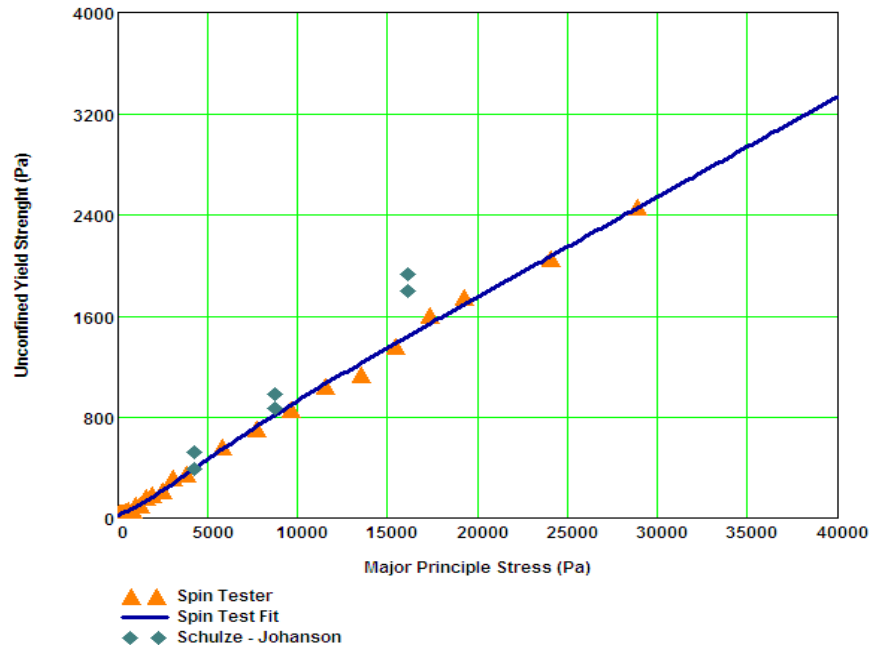

**Figure 6. Comparison of the unconfined yield strength of FMC PH-102 MCC measured with the Schulze direct shear method and the new test technique (SSSpinTester)**

We measured strength values down to about 4,000 Pa major principle stress and may have been able to obtain lower values, possibly around 2,000 Pa, using the Schulze tester but, the data was scattered. However, just as with other materials, the SSSpinTester method allowed us to acquire 14 points between 4,000 Pa and 30 Pa (Figure 7). We also computed the strength from the observed arching dimension of about 1.77 cm. This small arching dimension was caused by a very small strength value of 28.6 Pa at a stress level of 34.3 Pa. Please note that, although this stress level is very low, the measured strength data values obtained from the SSSpinTester still result in interpolation and not extrapolation to reach these values. Thus, this new method can measure directly the arching tendency of FMC's PH-102 MCC powder with good accuracy. The strength data interpolated from the SSSpinTester resulted in a computed arching dimension of 1.81 cm while the observed arching dimension was 1.77 cm.

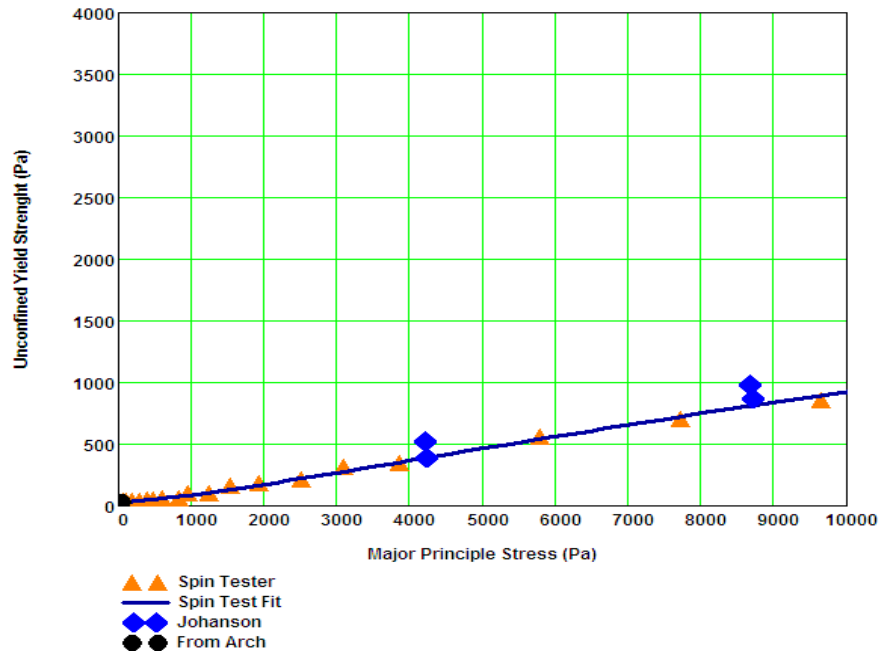

**Figure 7. Comparison of the low stress unconfined yield strength of FMC PH-102 MCC measured with the Schulze direct shear method and the new test technique (SSSpinTester)**

## Conclusions

The new test technique based on the use of centrifugal force to measure strength of bulk materials provides data comparable to data measured using traditional testers for stress levels that these traditional testers can achieve. However, this new methodology also allows measurement at major principle stress values 2 orders of magnitude lower than are currently possible with traditional test techniques. As a result, this test method can provide accurate strength data for moderately free flowing materials, predict accurately the arching potential in process equipment even in small diameter hoppers, and quantify strength values comparable to those that might cause flow problems when filling capsules and tablet press dies. Other test techniques require significant extrapolation (at least one order of magnitude) to make any credible arching predictions or flow behavior predictions in capsule filling or tablet filling. There is no extrapolation needed with this new methodology. The physical observations causing flow problems in equipment are obtained by interpolation of the SSSPinTester data. For the very first time, data measured by a strength measurement device bounds the conditions observed in real industrial systems. These strength measurements are also possible with just 0.1 cc of material so that a complete flow function characterization of the material can be done on 0.6 cc of material in about 30 minutes.

It is expected that this new tester will significantly extend the accuracy of process prediction for cohesive materials. However, this is just the tip of the iceberg. The small

amount of material required for the test makes it possible to correlate strength measured from single samples collected from capsules to fill (weight variation) behavior. We can measure the strength of the material in a capsule directly, and compare this to the weight in that particular capsule, thereby allowing researchers to develop strong correlations between weight fluctuations in packing systems and cohesive strength.

Strength can now be measured on the same scrutiny scale as the smallest packages that industry now uses (i.e. pills). At the same time, the large pressure strength tests (above 2,000 Pa) correlate well with those obtained from traditional techniques. This suggests that data obtained from this methodology could be used to design processes with very large bins and hoppers, while at the same time be applicable to design of very small feed systems creating individual pills or small packages.

The ability to measure strengths at low stress values also suggests that this data may be applicable to regimes such as material flowing down a pile where cohesion at very low stress values governs the segregation of material during process operation. This will create a new venue to explore the relationship between bulk flow properties and particle scale behaviors that currently cost industry billions in lost revenue and product due to segregation and quality issues.

This tester will be invaluable to the formulator that must create a product with the right cohesion to prevent segregation while still maintaining enough free flowing ability to successfully fill the desired package size.

Finally, cohesion of fine powders is what prevents them from being easily fluidized. However, the solids stress level in a fluidized condition is extremely low. Until now, we have not been able to measure the strength of powder at stress levels in fluid bed systems. To date, we have been able to infer cohesive properties through repose angle measurements of semi-fluidized materials or changes in torque measurements in fluid bed system with cohesive material. However, we have not been able to obtain these properties through direct measurement. The SSSpinTester will provide those dealing with fluid beds a tool to directly measure the parameter causing flow problems at stress level expected in the beds. It can lead to new models describing fluidization of cohesive materials as well as provide the ability to determine, in quality control mode, if a catalyst has expended its useful life in a fluid bed device.

Because the SSSpinTester needs just 5 minutes for one strength measurement, and minimal training to use, the tester lends itself to quality control measurements. A 5 minute measurement window will allow quality control personnel to monitor process changes in real time for optimal control of many solid flow processes.

## References

1. Akers, R. J., *The certification of a limestone for Jenike shear testing*. Community Bureau of Reference, Brussels, Belgium, 1992.
2. ASTM, *Standard shear test method for bulk solids using the Schulze ring shear tester*. Annual book of ASTM standards, 04.09 no D6773-02. ASTM, Philadelphia, USA, 2002.
3. EFCE, *Standard shear testing technique for particulate solids using the Jenike shear cell*. Working Party on the Mechanics of Particulate Solids. The Institution of Chemical Engineers, Rugby, UK, 1989.
4. Jenike, A. W. *Storage and flow of solids: Bulletin 123*. University of Utah, Salt Lake City, USA, 1964.
5. Saraber, F., Enstad, G. G., Haaker, G., *Investigations on the anisotropic yield behavior of a cohesive bulk solid*. Powder Technology, 64(3), p. 183-190, 1991.
6. Verwijs, Marinus Jacobus, *Stick-slip in powder flow: a quest for coherence length*, PhD Thesis, University of Florida, 2005.

